

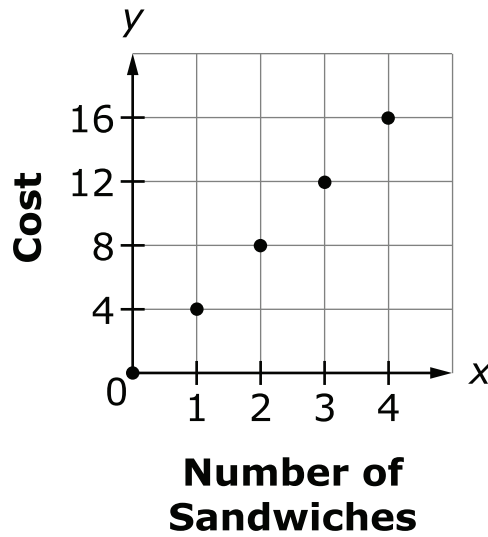

1. Use the information shown in the graph to complete the sentences.



Part A

Select the ordered pair that would correctly complete the sentence.

The point (____, ____) represents the unit rate.

- A. (0, 0)
- B. (1, 4)
- C. (2, 8)
- D. (3, 12)
- E. (4, 16)

Part B

Circle one number from Box A for blank A and one number from Box B for blank B to correctly complete the sentence.

The point (3, 12) means that for \$ A you can buy B sandwiches.

Box A	Box B
3	3
12	12



2. Which expression is equivalent to $\frac{12}{5}x - 2$?

A. $\frac{12x - 2}{5}$

B. $2\left(\frac{2}{5}x - 1\right)$

C. $\frac{2}{5}(6x - 1)$

D. $\frac{1}{5}(12x - 10)$

3. The first column contains five pairs of relationships. Determine if each pair forms a proportional relationship. Draw an **X** under "Proportional" or "Not Proportional" for each relationship in the table.

	Proportional	Not Proportional
3 games played in 2.5 hours and 9 games played in 7.5 hours		
18 points scored in 3 games and 20 points scored in 5 games		
2 apples for \$1.50 and 8 apples for \$6.50		
\$35.00 for 12.5 gallons of gasoline and \$16.80 for 6 gallons of gasoline		
15 miles from home after 20 minutes and 36 miles from home after 48 minutes		



4. Chris has \$1500 in the bank and takes out $\frac{1}{3}$ of the money.

He decides to use $\frac{3}{5}$ of the money he took from his account to pay part of a \$700 debt. After he makes this payment, how much, in dollars, does he still owe?

Write your answer in the space provided.

5. Trinity operates a lemonade stand every weekend. This weekend, she made 45% more money than the previous weekend. The previous weekend she made x dollars.

Write an expression that shows how much money Trinity made this weekend in the space provided.

6. A recipe for 1 pumpkin pie calls for $1\frac{1}{4}$ cups of sugar. Alaina has only $\frac{1}{2}$ cup of sugar and she needs to make 4 pumpkin pies.

How much more sugar will Alaina need to make all 4 pies?

Write your answer in the space provided.



7. The menu shows the prices for food and drink at a stadium. Customers can purchase separate items or choose from four combination (combo) packages. Combos are sold at a discounted price, lower than the price would be if each item in the combo were bought separately.

Stadium Menu

Separate Item Prices (\$)				Combo Prices (\$)	
Hamburger	6.50	Popcorn	3.00	Combo 1	10.00
Hot Dog	4.00	Water	3.00	Combo 2	10.25
Nachos	5.50	Soda	3.50	Combo 3	10.50
Peanuts	4.50	-	-	Combo 4	13.00

Part A

The items in combo 1 and combo 3 are given in the table. For each combo, determine the amount of the discount compared to purchasing each item in the combo separately, and then determine the percent discount. Round to the nearest whole percent.

Combo	Items Included	Discount Amount (\$)	Percent Discount (%)
1	Nachos, popcorn, and water		
3	Peanuts, popcorn, and soda		

Item continues on next page.



Stadium Menu

Separate Item Prices (\$)				Combo Prices (\$)	
Hamburger	6.50	Popcorn	3.00	Combo 1	10.00
Hot Dog	4.00	Water	3.00	Combo 2	10.25
Nachos	5.50	Soda	3.50	Combo 3	10.50
Peanuts	4.50	-	-	Combo 4	13.00

Part B

The combined sales for combo 3 and combo 4 on one particular day totaled \$1586.00. The number of combo 2 packages sold was 13 more than $\frac{1}{4}$ of the total number of all of the combos sold. The table is missing some information. Complete the table using the information given.

Combo	Items Included	Number Sold	Amount Earned (\$)
1	Nachos, popcorn, and water		
2	Hot dog, peanuts, and soda	88	902
3	Peanuts, popcorn, and soda		
4	Hamburger, nachos, and water	59	767

Part C

How much more money would the stadium have earned in sales if combos were not offered and the same number of items from all the combos were purchased individually?

Write your answer in the space provided.



8. Jerry is mowing his lawn. It takes him $\frac{1}{6}$ of an hour to mow $\frac{3}{20}$ of his yard. How much time will it take him to mow the entire yard?

A. $\frac{19}{60}$ hr

B. $\frac{9}{10}$ hr

C. $\frac{10}{9}$ hr

D. $\frac{10}{3}$ hr



9. Each of the three tables shows a relationship.

Cost of Movies

Number of Movies	Cost (\$)
1	\$10
2	\$15
3	\$20
4	\$25

Photo Album

Number of Pages	Number of Pictures
1	15
2	30
3	55
4	75

Minutes Read

Number of Days	Minutes Read
1	20
2	40
3	60
4	80

For each of the sentences shown below, circle the answer in the box below the sentence that would correctly complete the sentence.

The table that shows a proportional relationship is the table.

Box A
Cost of Movies
Photo Album
Minutes Read

The constant of proportionality is .

Box B
5
10
15
20



- 10.** Last month, Karmin made \$480 working for 30 hours. This month, she will get a 15% increase in the amount she earns per hour. What will be her hourly rate, in dollars per hour, after the raise?

Write your answer in the space provided.

- 11.** Audra makes and sells bracelets. It costs her \$8 to make a bracelet, and she sells them at a markup of 210%. Audra wants to have a sale, so she marks all of her bracelets 20% off the normal selling price. What will be the price of each bracelet during the sale?
- A.** \$15.20
 - B.** \$16.80
 - C.** \$19.84
 - D.** \$23.20



12. Over the summer, Marty read 4 times as many pages as the number of pages Nelson and Jennifer read combined. Marty read 1860 pages and Nelson read 240 pages.

Part A

Select an equation that could be solved to find the number of pages, p , Jennifer read.

- A. $1860 + 240 = 4p$
- B. $4(240 + p) = 1860$
- C. $1860 - (960 \div 4) = p$
- D. $240 + 4p = 1860$

Part B

How many pages did Jennifer read?

Write your answer in the space provided.



1. Use the information shown in the graph to complete the sentences.

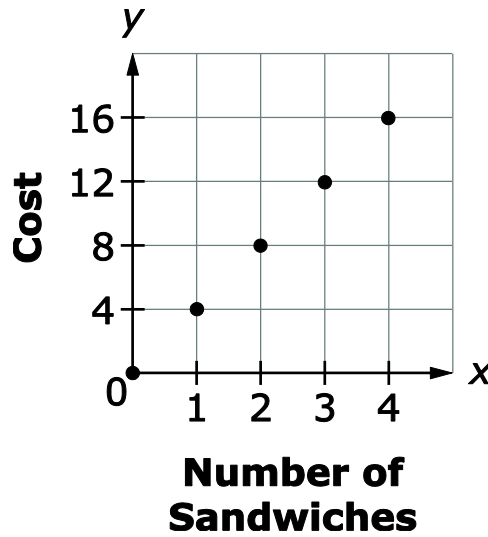

Part A

Select the ordered pair that would correctly complete the sentence.

The point (____, ____) represents the unit rate.

- A. (0, 0)
- B.* (1, 4)**
- C. (2, 8)
- D. (3, 12)
- E. (4, 16)

Part B

Circle one number from Box A for blank A and one number from Box B for blank B to correctly complete the sentence.

The point (3, 12) means that for \$ **A** you can buy **B** sandwiches.

Box A	Box B
3	*3
*12	12



2. Which expression is equivalent to $\frac{12}{5}x - 2$?
- A. $\frac{12x - 2}{5}$
- B. $2\left(\frac{2}{5}x - 1\right)$
- C. $\frac{2}{5}(6x - 1)$
- D.* $\frac{1}{5}(12x - 10)$

3. The first column contains five pairs of relationships. Determine if each pair forms a proportional relationship. Draw an **X** under "Proportional" or "Not Proportional" for each relationship in the table.

	Proportional	Not Proportional
3 games played in 2.5 hours and 9 games played in 7.5 hours	x	
18 points scored in 3 games and 20 points scored in 5 games		x
2 apples for \$1.50 and 8 apples for \$6.50		x
\$35.00 for 12.5 gallons of gasoline and \$16.80 for 6 gallons of gasoline	x	
15 miles from home after 20 minutes and 36 miles from home after 48 minutes	x	



4. Chris has \$1500 in the bank and takes out $\frac{1}{3}$ of the money.

He decides to use $\frac{3}{5}$ of the money he took from his account to pay part of a \$700 debt. After he makes this payment, how much, in dollars, does he still owe?

Write your answer in the space provided.

5. Trinity operates a lemonade stand every weekend. This weekend, she made 45% more money than the previous weekend. The previous weekend she made x dollars.

Write an expression that shows how much money Trinity made this weekend in the space provided.

6. A recipe for 1 pumpkin pie calls for $1\frac{1}{4}$ cups of sugar. Alaina has only $\frac{1}{2}$ cup of sugar and she needs to make 4 pumpkin pies.

How much more sugar will Alaina need to make all 4 pies?

Write your answer in the space provided.



7. The menu shows the prices for food and drink at a stadium. Customers can purchase separate items or choose from four combination (combo) packages. Combos are sold at a discounted price, lower than the price would be if each item in the combo were bought separately.

Stadium Menu

Separate Item Prices (\$)				Combo Prices (\$)	
Hamburger	6.50	Popcorn	3.00	Combo 1	10.00
Hot Dog	4.00	Water	3.00	Combo 2	10.25
Nachos	5.50	Soda	3.50	Combo 3	10.50
Peanuts	4.50	-	-	Combo 4	13.00

Part A

The items in combo 1 and combo 3 are given in the table. For each combo, determine the amount of the discount compared to purchasing each item in the combo separately, and then determine the percent discount. Round to the nearest whole percent.

Combo	Items Included	Discount Amount (\$)	Percent Discount (%)
1	Nachos, popcorn, and water	1.50	13
3	Peanuts, popcorn, and soda	0.50	5

Item continues on next page.



Stadium Menu

Separate Item Prices (\$)				Combo Prices (\$)	
Hamburger	6.50	Popcorn	3.00	Combo 1	10.00
Hot Dog	4.00	Water	3.00	Combo 2	10.25
Nachos	5.50	Soda	3.50	Combo 3	10.50
Peanuts	4.50	-	-	Combo 4	13.00

Part B

The combined sales for combo 3 and combo 4 on one particular day totaled \$1586.00. The number of combo 2 packages sold was 13 more than $\frac{1}{4}$ of the total number of all of the combos sold. The table is missing some information. Complete the table using the information given.

Combo	Items Included	Number Sold	Amount Earned (\$)
1	Nachos, popcorn, and water	75	750.00
2	Hot dog, peanuts, and soda	88	902
3	Peanuts, popcorn, and soda	78	819.00
4	Hamburger, nachos, and water	59	767

Part C

How much more money would the stadium have earned in sales if combos were not offered and the same number of items from all the combos were purchased individually?

Write your answer in the space provided.

423.50

Students will receive credit if an incorrect solution for one part of the performance task is used correctly to solve another part of the task.



8. Jerry is mowing his lawn. It takes him $\frac{1}{6}$ of an hour to mow $\frac{3}{20}$ of his yard. How much time will it take him to mow the entire yard?

A. $\frac{19}{60}$ hr

B. $\frac{9}{10}$ hr

C.* $\frac{10}{9}$ hr

D. $\frac{10}{3}$ hr



9. Each of the three tables shows a relationship.

Cost of Movies

Number of Movies	Cost (\$)
1	\$10
2	\$15
3	\$20
4	\$25

Photo Album

Number of Pages	Number of Pictures
1	15
2	30
3	55
4	75

Minutes Read

Number of Days	Minutes Read
1	20
2	40
3	60
4	80

For each of the sentences shown below, circle the answer in the box below the sentence that would correctly complete the sentence.

The table that shows a proportional relationship is the table.

Box A
Cost of Movies
Photo Album
*Minutes Read

The constant of proportionality is .

Box B
5
10
15
*20



- 10.** Last month, Karmin made \$480 working for 30 hours. This month, she will get a 15% increase in the amount she earns per hour. What will be her hourly rate, in dollars per hour, after the raise?

Write your answer in the space provided.

- 11.** Audra makes and sells bracelets. It costs her \$8 to make a bracelet, and she sells them at a markup of 210%. Audra wants to have a sale, so she marks all of her bracelets 20% off the normal selling price. What will be the price of each bracelet during the sale?
- A.** \$15.20
- B.** \$16.80
- C.* \$19.84**
- D.** \$23.20



12. Over the summer, Marty read 4 times as many pages as the number of pages Nelson and Jennifer read combined. Marty read 1860 pages and Nelson read 240 pages.

Part A

Select an equation that could be solved to find the number of pages, p , Jennifer read.

- A. $1860 + 240 = 4p$
- B.* $4(240 + p) = 1860$
- C. $1860 - (960 \div 4) = p$
- D. $240 + 4p = 1860$

Part B

How many pages did Jennifer read?

Write your answer in the space provided.



1. Evaluate:

$$4\frac{2}{3} - \left(-1\frac{4}{5}\right)$$

A. $-7\frac{2}{15}$

B. $2\frac{13}{15}$

C. $6\frac{7}{15}$

D. $7\frac{2}{15}$

2. Solve for m :

$$-\frac{2}{9}m + 12 = -8$$

Write your answer in the space provided.

3. While on a camping trip, Calvin was monitoring the temperature.

- In the afternoon, the temperature was -4°C .
- As the evening progressed, the temperature dropped 7°C .
- By mid-morning the next day, the temperature had risen 3°C .

What was the temperature, in degrees Celsius, after these changes?

Write your answer in the space provided.



4. A square garden has sides that are 10 feet in length.

Draw a scale drawing of the garden using a scale of 3 centimeters = 5 feet.

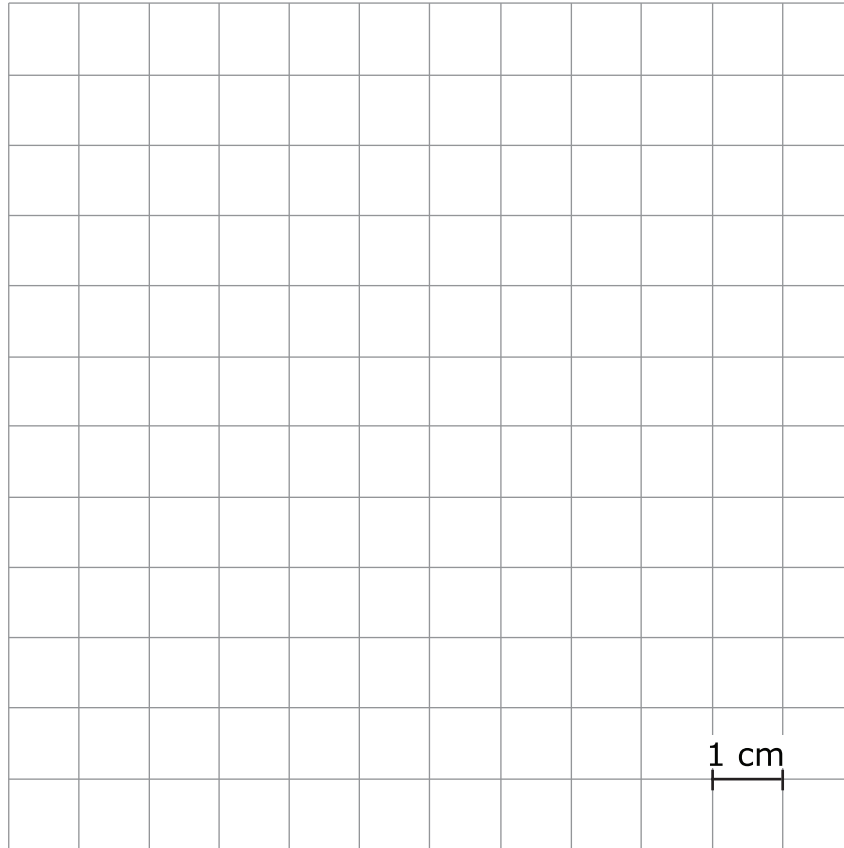



5. At a local gym, a random sample of 75 members took a survey about their favorite type of exercise.

Gym Survey Results

Type	Number of Members
Bicycling	18
Exercise Classes	22
Running on Treadmill	15
Weight Lifting	20

There are 350 total gym members. Based on the results of the survey, what is the **most** reasonable estimate for the number of gym members who prefer running on the treadmill?

- A. 23
- B. 70
- C. 85
- D. 93
6. Look at the rational numbers in both lists.
Match the fraction in the first column with the equivalent decimal in the second column.

Fractions

Decimals

$$\frac{5}{11}$$

$$0.375$$

$$0.37\bar{5}$$

$$\frac{3}{8}$$

$$0.4\bar{5}$$

$$0.45$$



7. The members of two running clubs entered their daily running totals into a computer program. The leaders of the two clubs randomly selected 25 days of the year and created box-and-whisker plots showing the total number of miles run by club members on the 25 selected days.

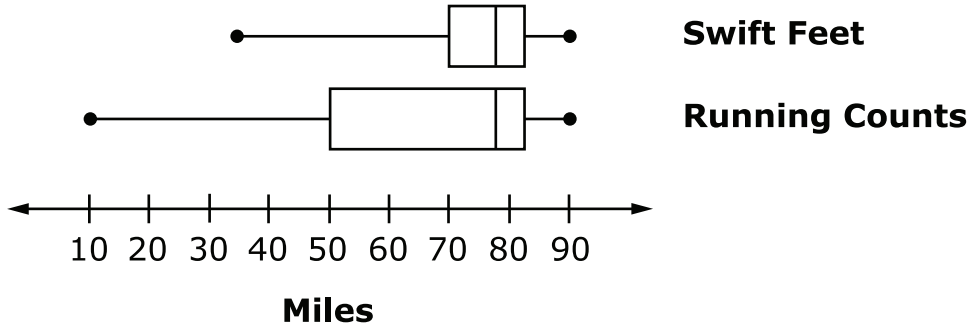

Which inference about the running groups is valid based on the samples given?

- A. The Swift Feet club has fewer members than the Running Counts club.
 - B. The members of the Running Counts club run more slowly than the members of the Swift Feet club.
 - C. The median number of miles run by members of both clubs was close to 80 miles.
 - D. The total miles run by members of both clubs vary by about the same amount.
8. A right square pyramid is sliced by a horizontal plane parallel to the base. Draw a possible plane section of the right square pyramid as described.

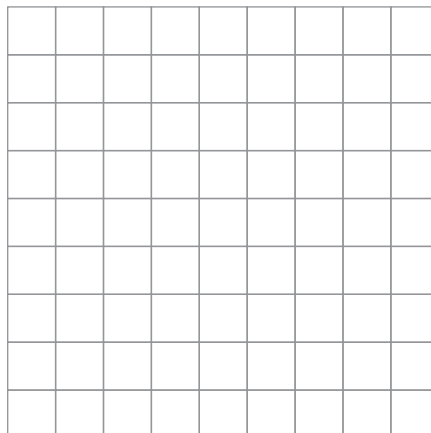



9. Nancy is buying a new pair of boots. The store is having a sale and all boots are 20% off.

Circle **one** value from the box below each sentence to correctly complete the sentence.

An expression that can represent the sale price of the boots is A, where x is the original price of the boots.

Box A
$0.2x$
$0.8x$
$1.2x$

This means the sale price of the boots is B of the original cost.

Box B
20%
80%
120%

10. Which situation is **best** described by this number line?

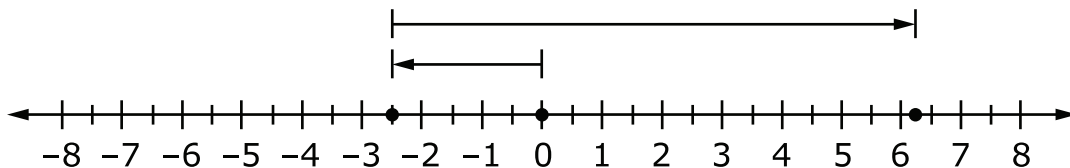

- A. Ryder owed his mom \$2.50. He does some chores and makes \$6.25.
- B. Ryder had \$6.25. He needs to buy school supplies and ends up owing his mother \$2.50.
- C. Ryder owed his mom \$2.50. He babysits his sister and makes \$8.75.
- D. Ryder owed his mom \$2.50. He also owes his father \$8.75.



11. Select **all** expressions shown that are equivalent to $\frac{3}{5}a + 10$.

A. $\frac{1}{5}a + 10 + \frac{2}{5}a$

B. $a\left(\frac{3}{5} + 10\right)$

C. $14 + \frac{3}{5}a - 4$

D. $\frac{1}{5}(3a + 50)$

E. $10 + \frac{2}{5}a - a + \frac{1}{5}a$



- 12.** Karen gets 3 books from her book club for \$12. She creates a graph to show the relationship between the number of books and the total cost of the books. Points on the graph include $(0,0)$, $(1, 4)$, $(2, 8)$, and $(3, 12)$.

Circle **one** coordinate or phrase from the box below each sentence to correctly complete the sentence.

The ordered pair **A** represents unit rate.

Box A
$(0, 0)$
$(1, 4)$
$(2, 8)$
$(3, 12)$

The x-value of the ordered pair represents the **B**.

Box B
number of books
cost of the books

The y-value of the ordered pair represents the **C**.

Box C
number of books
cost of the books



13. What is the value of x ?

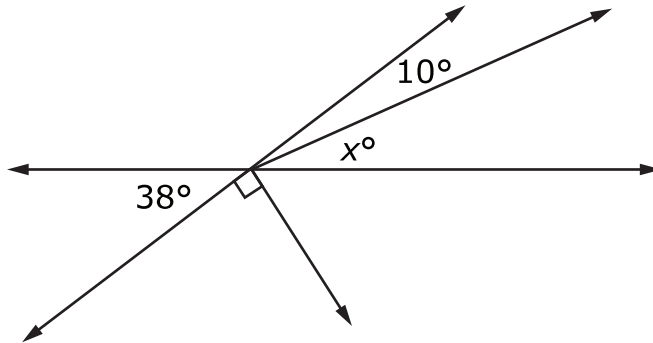

Write your answer in the space provided.

**Directions**

Subtest 2 of this Practice Test booklet contains sample items for Grade 7 Math. Write your answers in this Practice Test booklet.

You MAY use a calculator in Subtest 2 of this test booklet.

14. Select **all** of the expressions that are equivalent to $\frac{2}{3}(9x + 6) - \frac{1}{2}(8x - 4)$.

A. $2(x + 1)$

B. $2x + 6$

C. $2x + 2$

D. $2(x + 3)$

E. $8x$

15. A random sample of 40 blocks was removed from a container. The blocks removed included 9 black, 15 red, 11 yellow, and 5 orange blocks.

Based on the experimental results, determine the probability of removing each color of block from the container.

Draw an **X** in the table to match each color with the probability for that color.

	$\frac{1}{8}$	$\frac{3}{8}$	0.225	0.275
Black				
Red				
Yellow				
Orange				



16. The measurements of a figure are shown.

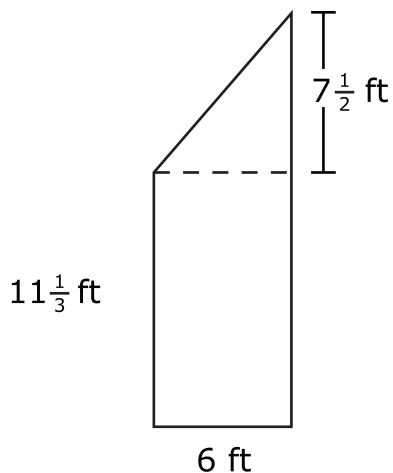

What is the area, in square feet, of the figure?

Write your answer in the space provided.

17. Sandals are on sale for 30% off. The original price of one pair of sandals is \$15.

What is the total cost, in dollars, of **two** pairs of sandals at the sale price and including 7% sales tax?

Write your answer in the space provided.



18. Select **all** that represent a proportional relationship.

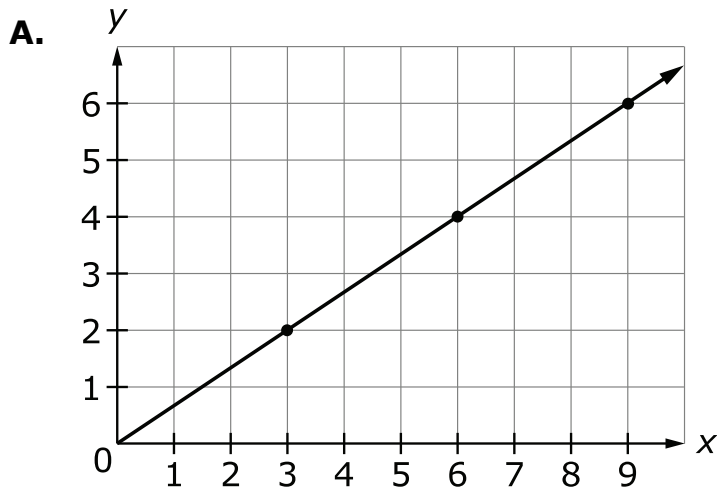

B.

x	y
2	3
4	4
6	5
8	6

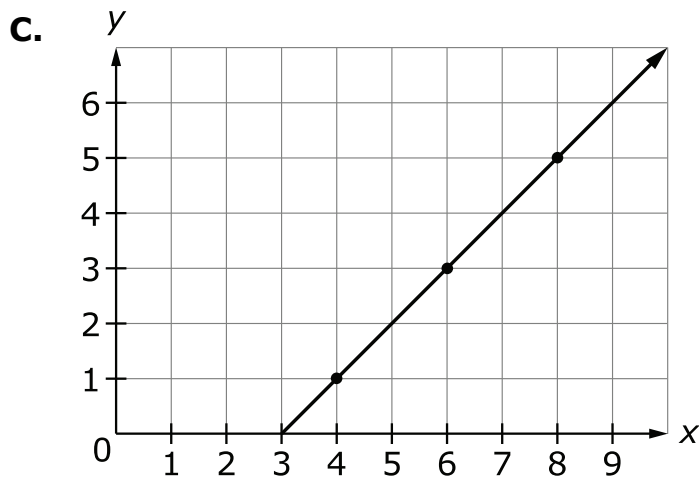

D.

x	y
3	1
6	2
9	3
12	4



- 19.** In the year 2010, the population of Kingsford was 8000. By 2014 the population had increased by 15% and $\frac{2}{5}$ of the population was age 12 or under.

How many people in Kingsford were age 12 or under in the year 2014?

- A.** 1200
B. 3200
C. 3680
D. 5520
- 20.** Margaret is placing a picture on a wall that is $7\frac{1}{2}$ feet long. The picture is 27 inches across and will be hung in the center of the wall, as shown in the drawing.

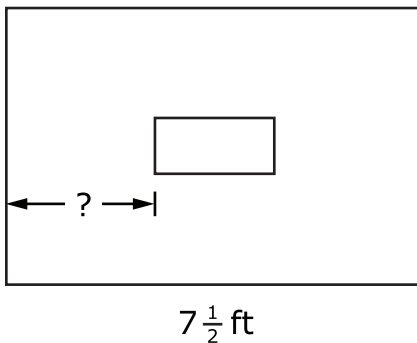

What is the distance, in inches, from one edge of the wall to the picture?

Write your answer in the space provided.



- 21.** Nathan conducted a probability experiment in which he dropped 5 toothpicks at the same time. He recorded the number of toothpicks that were touching when they landed. He then picked up the toothpicks and repeated the experiment. After dropping the toothpicks and recording the results 50 times, Nathan concluded that it was more likely than not that at least 2 toothpicks would be touching when they landed. He also observed that sometimes no toothpicks were touching. Which **best** represents the probability that at least 2 toothpicks will be touching when they land?

- A. $\frac{1}{4}$
- B. $\frac{1}{2}$
- C. $\frac{3}{4}$
- D. 1

- 22.** The lengths or angles given represent the sides or angles of a triangle.

For each set of angles or sides, draw an **X** in the appropriate box:
 Unique Triangle, More Than One Triangle, or No Triangle.

	Unique Triangle	More Than One Triangle	No Triangle
5 cm, 10 cm, 12 cm			
40°, 50°, 80°			
8 ft, 12 ft, 20 ft			
28°, 51°, 101°			



- 23.** Ms. Allen filled a glass jar with marbles. Students guessed the number of marbles in the jar.

Jen guessed there were 127 marbles in the jar. The jar contained 132 marbles.

To the nearest tenth of a percent, what is the percentage of error for Jen's guess?

Write your answer in the space provided.



24. Margo records the relationship between the amounts of raisins and peanuts she mixes to create different batches of her trail mix.

Batch	A	B	C	D	E
Ounces of raisins	1	2	3	4	5
Cups of peanuts	1.25	2.5	3.75	5	6.25

Using the information provided in the table, circle **one** choice from the box below each sentence to correctly complete the sentence.

The ordered pair has a y -coordinate that is the constant of proportionality for the relationship.

Box A
(1, 1.25)
(2, 2.5)
(4, 5)

Based on the proportional relationship, 8 ounces of raisins require cups of peanuts.

Box B
6.5
7.75
10
11.25



- 25.** The music preferences of a random sample of 75 middle-school students are recorded in the table. There are 1257 students in the middle school.

Music Preference Sample	
Music Type	Number of Students
Rock	19
Pop	27
Country	29

Select **two** statements that are valid for the entire middle school based on the information from the random sample.

- A.** Approximately 452 of the students prefer pop music.
- B.** Approximately 19 of the students prefer rock music.
- C.** Approximately 39% of the students prefer country music.
- D.** Approximately $\frac{1}{3}$ of the students prefer rock music.



1. Evaluate:

$$4\frac{2}{3} - \left(-1\frac{4}{5}\right)$$

A. $-7\frac{2}{15}$

B. $2\frac{13}{15}$

C.* $6\frac{7}{15}$

D. $7\frac{2}{15}$

2. Solve for m :

$$-\frac{2}{9}m + 12 = -8$$

Write your answer in the space provided.

3. While on a camping trip, Calvin was monitoring the temperature.

- In the afternoon, the temperature was -4°C .
- As the evening progressed, the temperature dropped 7°C .
- By mid-morning the next day, the temperature had risen 3°C .

What was the temperature, in degrees Celsius, after these changes?

Write your answer in the space provided.



4. A square garden has sides that are 10 feet in length.

Draw a scale drawing of the garden using a scale of 3 centimeters = 5 feet.

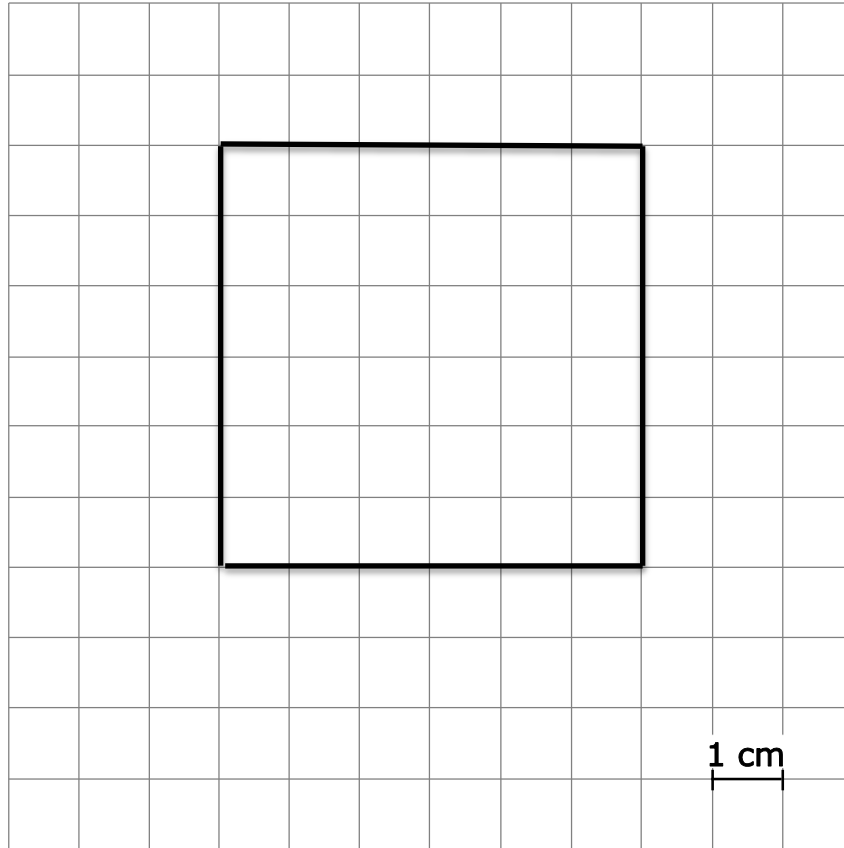

Square may be in any position but must be a 6 by 6 square.



5. At a local gym, a random sample of 75 members took a survey about their favorite type of exercise.

Gym Survey Results

Type	Number of Members
Bicycling	18
Exercise Classes	22
Running on Treadmill	15
Weight Lifting	20

There are 350 total gym members. Based on the results of the survey, what is the **most** reasonable estimate for the number of gym members who prefer running on the treadmill?

- A. 23
- B.* 70**
- C. 85
- D. 93
6. Look at the rational numbers in both lists.
Match the fraction in the first column with the equivalent decimal in the second column.

Fractions

Decimals

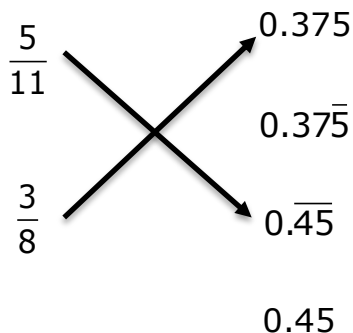



7. The members of two running clubs entered their daily running totals into a computer program. The leaders of the two clubs randomly selected 25 days of the year and created box-and-whisker plots showing the total number of miles run by club members on the 25 selected days.

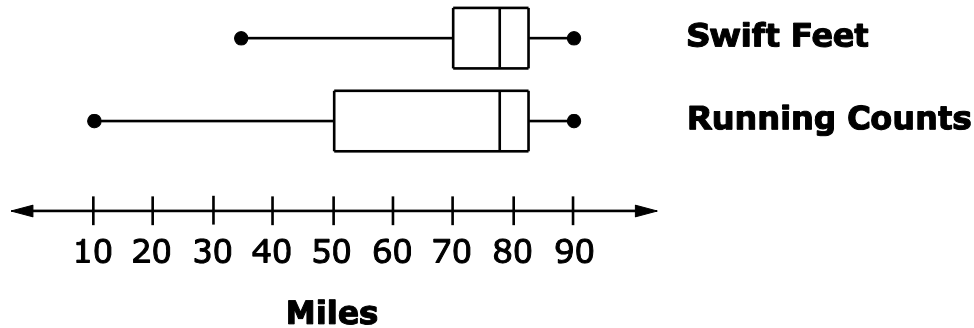

Which inference about the running groups is valid based on the samples given?

- A. The Swift Feet club has fewer members than the Running Counts club.
 - B. The members of the Running Counts club run more slowly than the members of the Swift Feet club.
 - C.* The median number of miles run by members of both clubs was close to 80 miles.**
 - D. The total miles run by members of both clubs vary by about the same amount.
8. A right square pyramid is sliced by a horizontal plane parallel to the base. Draw a possible plane section of the right square pyramid as described.

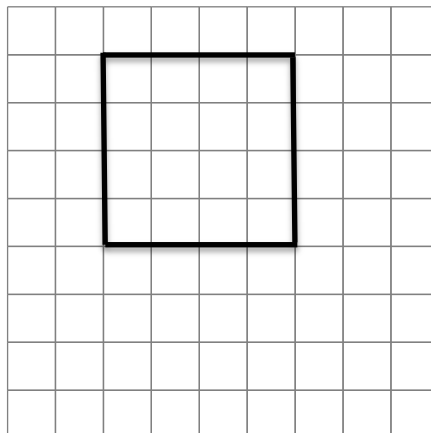

*Any square is correct.



9. Nancy is buying a new pair of boots. The store is having a sale and all boots are 20% off.

Circle **one** value from the box below each sentence to correctly complete the sentence.

An expression that can represent the sale price of the boots is A, where x is the original price of the boots.

Box A
$0.2x$
$*0.8x$
$1.2x$

This means the sale price of the boots is B of the original cost.

Box B
20%
$*80%$
120%

10. Which situation is **best** described by this number line?

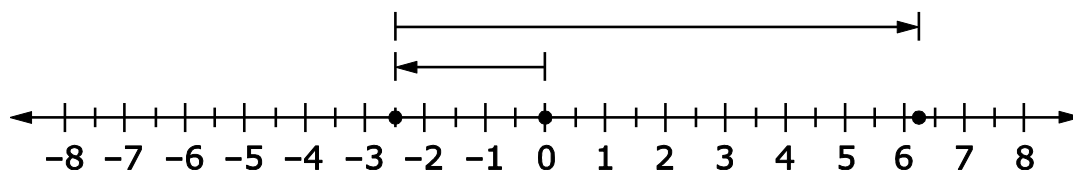

- A. Ryder owed his mom \$2.50. He does some chores and makes \$6.25.
- B. Ryder had \$6.25. He needs to buy school supplies and ends up owing his mother \$2.50.
- C.* Ryder owed his mom \$2.50. He babysits his sister and makes \$8.75.**
- D. Ryder owed his mom \$2.50. He also owes his father \$8.75.



11. Select **all** expressions shown that are equivalent to $\frac{3}{5}a + 10$.

A.* $\frac{1}{5}a + 10 + \frac{2}{5}a$

B. $a\left(\frac{3}{5} + 10\right)$

C.* $14 + \frac{3}{5}a - 4$

D.* $\frac{1}{5}(3a + 50)$

E. $10 + \frac{2}{5}a - a + \frac{1}{5}a$



- 12.** Karen gets 3 books from her book club for \$12. She creates a graph to show the relationship between the number of books and the total cost of the books. Points on the graph include $(0,0)$, $(1, 4)$, $(2, 8)$, and $(3, 12)$.

Circle **one** coordinate or phrase from the box below each sentence to correctly complete the sentence.

The ordered pair **A** represents unit rate.

Box A
$(0, 0)$
*$(1, 4)$
$(2, 8)$
$(3, 12)$

The x-value of the ordered pair represents the **B**.

Box B
*number of books
cost of the books

The y-value of the ordered pair represents the **C**.

Box C
number of books
*cost of the books



13. What is the value of x ?

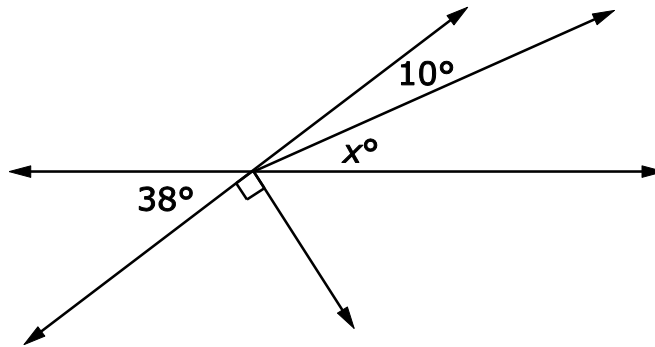

Write your answer in the space provided.



Directions

Subtest 2 of this Practice Test booklet contains sample items for Grade 7 Math. Write your answers in this Practice Test booklet.

You MAY use a calculator in Subtest 2 of this test booklet.

14. Select **all** of the expressions that are equivalent to $\frac{2}{3}(9x + 6) - \frac{1}{2}(8x - 4)$.
- A. $2(x + 1)$
 - B.* $2x + 6$
 - C. $2x + 2$
 - D.* $2(x + 3)$
 - E. $8x$

15. A random sample of 40 blocks was removed from a container. The blocks removed included 9 black, 15 red, 11 yellow, and 5 orange blocks.

Based on the experimental results, determine the probability of removing each color of block from the container.

Draw an **X** in the table to match each color with the probability for that color.

	$\frac{1}{8}$	$\frac{3}{8}$	0.225	0.275
Black			x	
Red		x		
Yellow				x
Orange	x			



16. The measurements of a figure are shown.

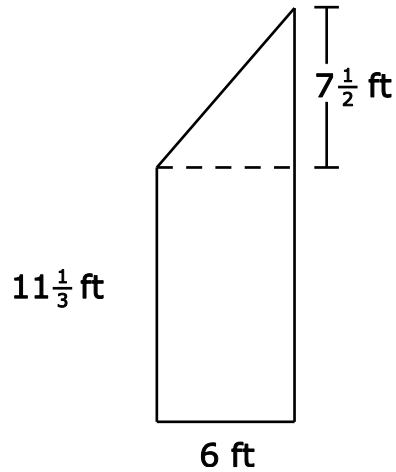

What is the area, in square feet, of the figure?

Write your answer in the space provided.

17. Sandals are on sale for 30% off. The original price of one pair of sandals is \$15.

What is the total cost, in dollars, of **two** pairs of sandals at the sale price and including 7% sales tax?

Write your answer in the space provided.



18. Select **all** that represent a proportional relationship.

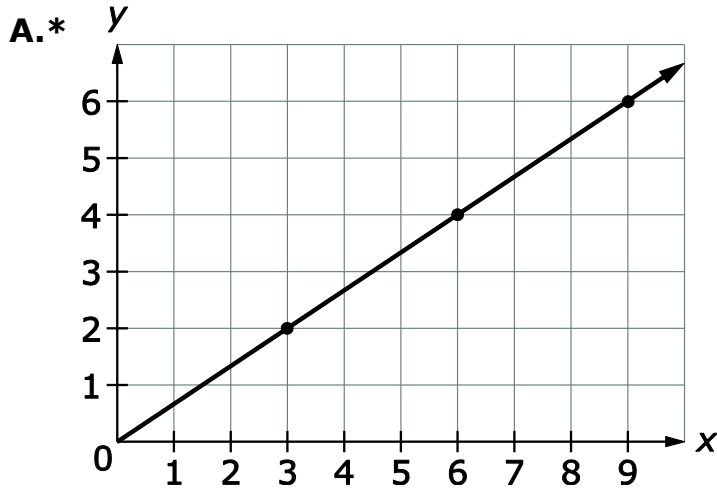

B.

x	y
2	3
4	4
6	5
8	6

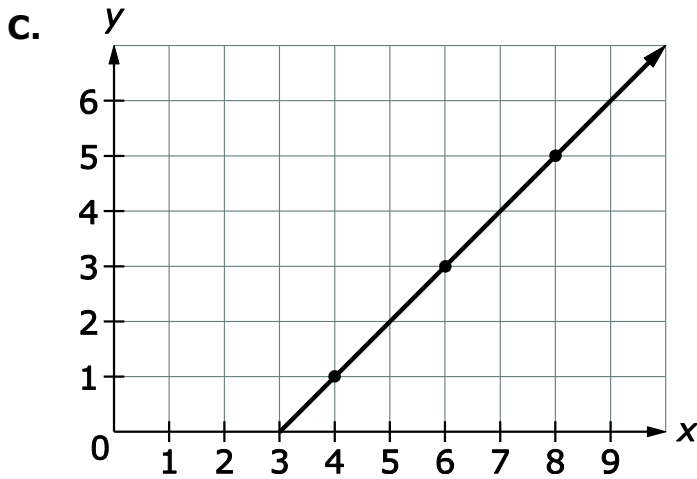

D.*

x	y
3	1
6	2
9	3
12	4



19. In the year 2010, the population of Kingsford was 8000. By 2014 the population had increased by 15% and $\frac{2}{5}$ of the population was age 12 or under.

How many people in Kingsford were age 12 or under in the year 2014?

- A. 1200
B. 3200
C.* 3680
D. 5520
20. Margaret is placing a picture on a wall that is $7\frac{1}{2}$ feet long. The picture is 27 inches across and will be hung in the center of the wall, as shown in the drawing.

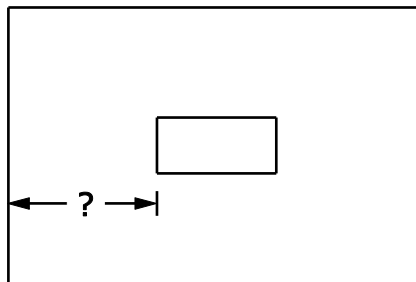

$7\frac{1}{2}$ ft

What is the distance, in inches, from one edge of the wall to the picture?

Write your answer in the space provided.

31.5 or an equivalent value



- 21.** Nathan conducted a probability experiment in which he dropped 5 toothpicks at the same time. He recorded the number of toothpicks that were touching when they landed. He then picked up the toothpicks and repeated the experiment. After dropping the toothpicks and recording the results 50 times, Nathan concluded that it was more likely than not that at least 2 toothpicks would be touching when they landed. He also observed that sometimes no toothpicks were touching. Which **best** represents the probability that at least 2 toothpicks will be touching when they land?

A. $\frac{1}{4}$

B. $\frac{1}{2}$

C.* $\frac{3}{4}$

D. 1

- 22.** The lengths or angles given represent the sides or angles of a triangle.

For each set of angles or sides, draw an **X** in the appropriate box:
Unique Triangle, More Than One Triangle, or No Triangle.

	Unique Triangle	More Than One Triangle	No Triangle
5 cm, 10 cm, 12 cm	x		
40°, 50°, 80°			x
8 ft, 12 ft, 20 ft			x
28°, 51°, 101°		x	



- 23.** Ms. Allen filled a glass jar with marbles. Students guessed the number of marbles in the jar.

Jen guessed there were 127 marbles in the jar. The jar contained 132 marbles.

To the nearest tenth of a percent, what is the percentage of error for Jen's guess?

Write your answer in the space provided.



24. Margo records the relationship between the amounts of raisins and peanuts she mixes to create different batches of her trail mix.

Batch	A	B	C	D	E
Ounces of raisins	1	2	3	4	5
Cups of peanuts	1.25	2.5	3.75	5	6.25

Using the information provided in the table, circle **one** choice from the box below each sentence to correctly complete the sentence.

The ordered pair $(\text{---} \mathbf{A} \text{---})$ has a y -coordinate that is the constant of proportionality for the relationship.

Box A
* (1, 1.25)
(2, 2.5)
(4, 5)

Based on the proportional relationship, 8 ounces of raisins require $(\text{---} \mathbf{B} \text{---})$ cups of peanuts.

Box B
6.5
7.75
* 10
11.25



25. The music preferences of a random sample of 75 middle-school students are recorded in the table. There are 1257 students in the middle school.

Music Preference Sample	
Music Type	Number of Students
Rock	19
Pop	27
Country	29

Select **two** statements that are valid for the entire middle school based on the information from the random sample.

- A.* Approximately 452 of the students prefer pop music.**
- B.** Approximately 19 of the students prefer rock music.
- C.* Approximately 39% of the students prefer country music.**
- D.** Approximately $\frac{1}{3}$ of the students prefer rock music.