

Mathematics

SESSION 1

You may use your reference sheet and MCAS ruler during this session.

You may **not** use a calculator during this session.



DIRECTIONS

This session contains eight multiple-choice questions and two short-answer questions. Mark your answers to these questions in the spaces provided in your Student Answer Booklet.

- 1 The scores of four friends who played a game are shown in the table below.

Game Scores

Name	Score
Maya	350
David	-150
Alisa	-450
Juan	250

Which list shows the scores in order from least to greatest?

- A. -150, 250, 350, -450
- B. -150, -450, 250, 350
- C. -450, -150, 250, 350
- D. -450, 350, 250, -150

- 2 On a trip, Lisa drove her car 283.4 miles using 8.9 gallons of gas. Which of the following estimates is closest to the number of miles per gallon of gas that Lisa's car used on her trip?

- A. 10 miles per gallon
- B. 20 miles per gallon
- C. 30 miles per gallon
- D. 40 miles per gallon

- 3 What is the value of the expression below?

$$6 + 4^3 \div 2$$

- A. 12
- B. 15
- C. 35
- D. 38

Question 4 is a short-answer question. Write your answer to this question in the box provided in your Student Answer Booklet. Do not write your answer in this test booklet. You may do your figuring in the test booklet.

- 4 What is the value of the expression below, when $n = 3$?

$$2.5n + 6$$

Mark your answers to multiple-choice questions 5 through 9 in the spaces provided in your Student Answer Booklet. Do not write your answers in this test booklet. You may do your figuring in the test booklet.

- 5 Leona had some marbles and some number cubes.

- Each marble weighed the same amount.
- Each number cube weighed $\frac{1}{2}$ ounce.

Leona placed 3 number cubes and 3 marbles on one side of a scale. Then she placed 1 number cube and 7 marbles on the other side to balance the scale, as shown below.

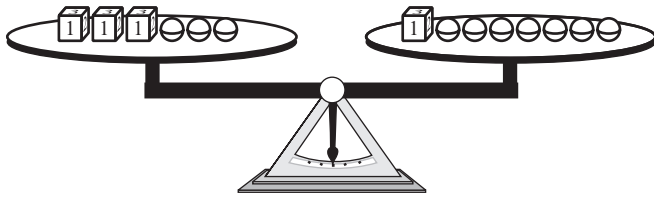

What was the weight of 1 marble?

- A. $\frac{1}{8}$ ounce
- B. $\frac{1}{4}$ ounce
- C. $\frac{1}{2}$ ounce
- D. 1 ounce

- 6 The table below shows the cost of renting a canoe at Parker Lakes for different numbers of hours.

Canoe Rental Cost

Number of Hours	Cost
1	\$ 7
2	\$ 9
3	\$11
4	\$13

Based on the data in the table, which statement correctly represents the cost of renting a canoe?

- A. The cost is \$3.25 per hour.
 - B. The cost is \$3.50 per hour.
 - C. The cost is a one-time fee of \$2 plus \$5 per hour.
 - D. The cost is a one-time fee of \$5 plus \$2 per hour.
- 7 The Philippines has a population of approximately 78,000,000. What is 78,000,000 written in scientific notation?
- A. 7.8×10^5
 - B. 7.8×10^6
 - C. 7.8×10^7
 - D. 7.8×10^8

- 8 Jack wrote the equation below on the board.

$$5\frac{1}{4} - 2\frac{3}{4} = 2\frac{1}{2}$$

Which of the following expressions could Jack use to show that the equation is true?

- A. $2\frac{3}{4} + 2\frac{1}{2}$
- B. $2\frac{1}{2} + 5\frac{1}{4}$
- C. $2\frac{1}{2} - 2\frac{3}{4}$
- D. $2\frac{3}{4} - 2\frac{1}{2}$

- 9 The graph below shows the relationship between the number of tickets sold for a band concert and the amount of money, in dollars, collected from the sales of the first 30 tickets.

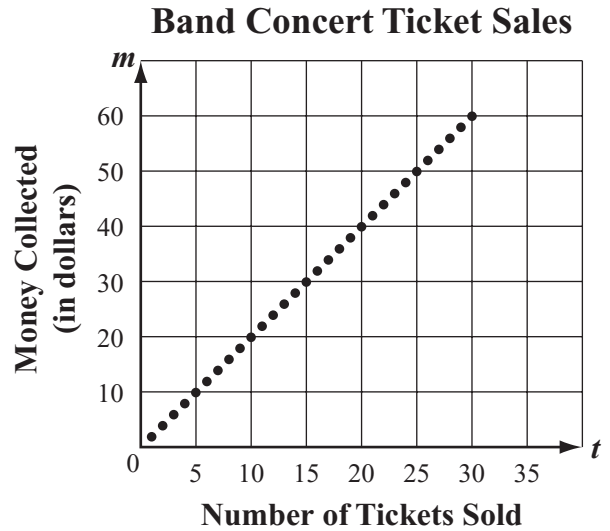

For the data in the graph, which of the following equations can be used to calculate m , the amount of money, in dollars, collected for t tickets sold?

- A. $m = \frac{1}{2}t$
- B. $m = 2t$
- C. $m = 5t$
- D. $m = 10t$

Question 10 is a short-answer question. Write your answer to this question in the box provided in your Student Answer Booklet. Do not write your answer in this test booklet. You may do your figuring in the test booklet.

- 10 The Venn diagram below shows the numbers of students in Logan's class who wore blue jeans, blue shirts, or a combination of both on Spirit Day.

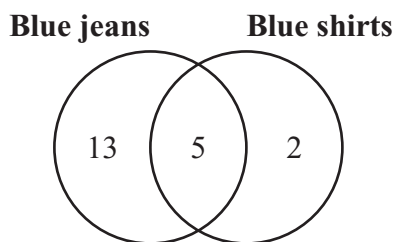

What was the total number of students who wore blue shirts?

Mathematics

SESSION 2

You may use your reference sheet and MCAS ruler during this session.

You may use a calculator during this session.



DIRECTIONS

This session contains five multiple-choice questions and two open-response questions. Mark your answers to these questions in the spaces provided in your Student Answer Booklet.

- 11** Kelly asked 200 seventh-grade students to name their favorite team sport. She made the graph below to record her results.

7th Grade Students' Favorite Sports

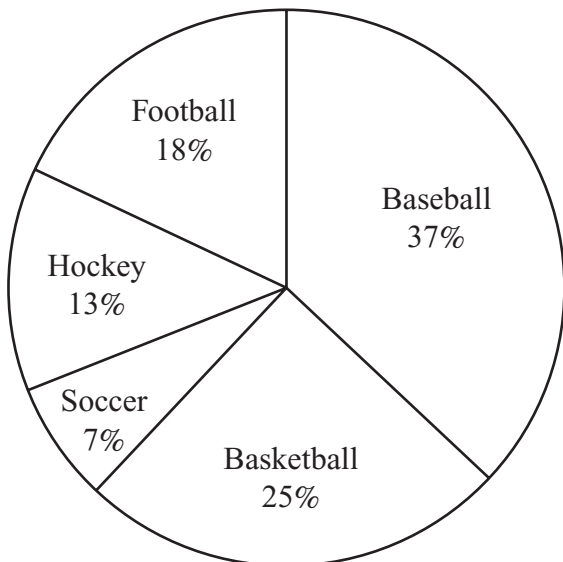

Based on the data in the graph, what was the total number of students who named football as their favorite sport?

- A. 18
- B. 36
- C. 40
- D. 50

- 12 A radio station awarded prizes to the top three winners of a contest.
- The first-place prize was \$2000.
 - The second-place prize was 30% less than the first-place prize.
 - The third-place prize was 30% less than the second-place prize.

Which table shows the three prize amounts in the radio contest?

A. **Radio Station Contest Prizes**

Contest Place	Prize Amount
first	\$2000
second	\$1970
third	\$1940

C. **Radio Station Contest Prizes**

Contest Place	Prize Amount
first	\$2000
second	\$1400
third	\$ 980

B. **Radio Station Contest Prizes**

Contest Place	Prize Amount
first	\$2000
second	\$1700
third	\$1400

D. **Radio Station Contest Prizes**

Contest Place	Prize Amount
first	\$2000
second	\$1400
third	\$ 800

- 13 In Ms. Crary's mathematics class, 2 out of every 5 students earned an A on the last test. A total of 35 students took the test.

Which of the following proportions can be used to find x , the number of students in Ms. Crary's class who earned an A on the last mathematics test?

A. $\frac{2}{35} = \frac{x}{5}$

B. $\frac{2}{35} = \frac{5}{x}$

C. $\frac{2}{5} = \frac{x}{35}$

D. $\frac{2}{5} = \frac{35}{x}$

Question 14 is an open-response question.

- **BE SURE TO ANSWER AND LABEL ALL PARTS OF THE QUESTION.**
- **Show all your work (diagrams, tables, or computations) in your Student Answer Booklet.**
- **If you do the work in your head, explain in writing how you did the work.**

Write your answer to question 14 in the space provided in your Student Answer Booklet.

- 14 Parallel lines n and p are intersected by transversal lines q and m , as shown in the figure below.

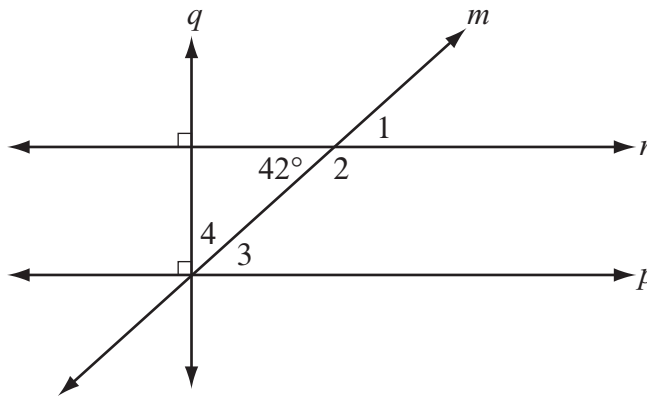

Lines q , m , and p intersect at a common point.

- What is the degree measure of $\angle 1$? Show or explain how you got your answer.
- What is the degree measure of $\angle 2$? Show or explain how you got your answer.
- What is the degree measure of $\angle 3$? Show or explain how you got your answer.
- What is the degree measure of $\angle 4$? Show or explain how you got your answer.

Mark your answers to multiple-choice questions 15 and 16 in the spaces provided in your Student Answer Booklet. Do not write your answers in this test booklet. You may do your figuring in the test booklet.

- 15 Haley has one spinner that is divided into three congruent sections and one spinner that is divided into four congruent sections, as shown below.

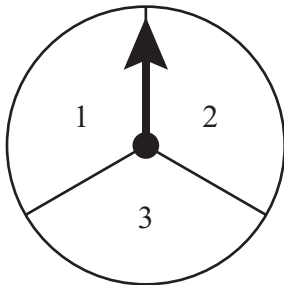

Spinner L

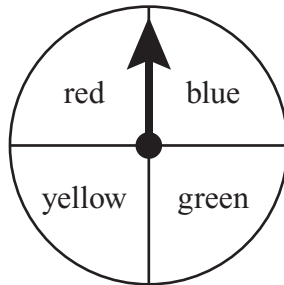

Spinner M

Haley will spin the arrow on each spinner one time. All the possible combinations that can occur are shown in the list below.

- | | | |
|-----------|-----------|-----------|
| 1, red | 2, red | 3, red |
| 1, blue | 2, blue | 3, blue |
| 1, green | 2, green | 3, green |
| 1, yellow | 2, yellow | 3, yellow |

What is the probability that the arrow on Spinner L will stop on a section with an odd number and the arrow on Spinner M will stop on the red section?

- A. $\frac{1}{6}$
- B. $\frac{1}{5}$
- C. $\frac{11}{12}$
- D. $\frac{3}{4}$

- 16 The price, in cents, of each item in a vending machine is shown in the stem-and-leaf plot below.

Prices of Items in Vending Machine

3	0 5
4	0 0 0 5
5	0 0 5 5 5
6	0 5
7	5 5 5 5
8	0
9	5

Key	
3 5	represents 35 cents

What is the range of the prices of the items?

- A. 55 cents
- B. 60 cents
- C. 65 cents
- D. 75 cents

Question 17 is an open-response question.

- **BE SURE TO ANSWER AND LABEL ALL PARTS OF THE QUESTION.**
- **Show all your work (diagrams, tables, or computations) in your Student Answer Booklet.**
- **If you do the work in your head, explain in writing how you did the work.**

Write your answer to question 17 in the space provided in your Student Answer Booklet.

- 17** Ray had a block of wood in the shape of a rectangular prism. The block and its dimensions are shown below.

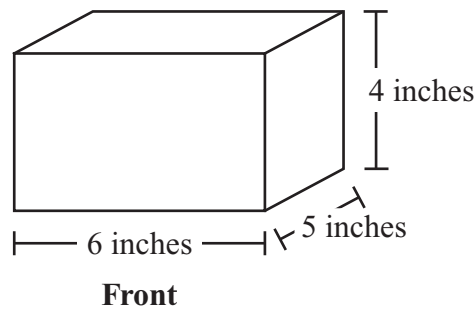

- a. Ray painted the front face of the block red. What is the area, in square inches, of the face he painted red? Show or explain how you got your answer.
- b. Ray painted the top and bottom faces of the block black. What is the area, in square inches, of the faces he painted black? Show or explain how you got your answer.
- c. Ray painted the other faces of the block white. What is the area, in square inches, of the faces he painted white? Show or explain how you got your answer.

Grade 7 Mathematics
Spring 2009 Released Items:
Reporting Categories, Standards, and Correct Answers*

Item No.	Page No.	Reporting Category	Standard	Correct Answer (MC/SA)*
1	191	<i>Number Sense and Operations</i>	7.N.1	C
2	191	<i>Number Sense and Operations</i>	7.N.7	C
3	191	<i>Number Sense and Operations</i>	7.N.5	D
4	192	<i>Patterns, Relations, and Algebra</i>	7.P.2	13.5
5	193	<i>Patterns, Relations, and Algebra</i>	7.P.4	B
6	193	<i>Patterns, Relations, and Algebra</i>	7.P.1	D
7	193	<i>Number Sense and Operations</i>	7.N.3	C
8	194	<i>Number Sense and Operations</i>	7.N.6	A
9	194	<i>Patterns, Relations, and Algebra</i>	7.P.6	B
10	195	<i>Data Analysis, Statistics, and Probability</i>	7.D.1	7
11	196	<i>Data Analysis, Statistics, and Probability</i>	7.D.1	B
12	197	<i>Patterns, Relations, and Algebra</i>	7.P.1	C
13	198	<i>Patterns, Relations, and Algebra</i>	7.P.6	C
14	199	<i>Geometry</i>	7.G.3	
15	200	<i>Data Analysis, Statistics, and Probability</i>	7.D.3	A
16	200	<i>Data Analysis, Statistics, and Probability</i>	7.D.2	C
17	201	<i>Measurement</i>	7.M.3	

* Answers are provided here for multiple-choice items and short-answer items only. Sample responses and scoring guidelines for open-response items, which are indicated by shaded cells, will be posted to the Department's website later this year.