

MATHEMATICS

You may use the Mathematics Reference Sheet any time during the test.

1. Edison Elementary School has 823 students, Jefferson Middle School has 684 students, and Lincoln High School has 1,228 students. What is the **best** estimate, to the nearest hundred, of the total number of students at the three schools?

- A 2,500 students
 - B 2,600 students
 - C 2,700 students
 - D 2,900 students
-

2. An astronomer in Morocco spots a solar flare at 4 PM Morocco time. An astronomer in Texas spots the same solar flare. It is 5 hours earlier in Texas. What time was the solar flare spotted in Texas?

- A 10:00 AM
 - B 11:00 AM
 - C 1:00 PM
 - D 9:00 PM
-

3. Jean saw the following numbers on mailboxes.

71, 73, 75, 77, 79

How many of the numbers are prime?

- A 2
- B 3
- C 4
- D 5



MATHEMATICS

4. Sandra conducted a survey. She found that 28% of drivers turn on their headlights when driving during the day. Which fraction is equivalent to 28%?

- A $\frac{1}{28}$
 - B $\frac{2}{8}$
 - C $\frac{7}{25}$
 - D $\frac{18}{25}$
-

5. The coordinate grid below shows 4 points.

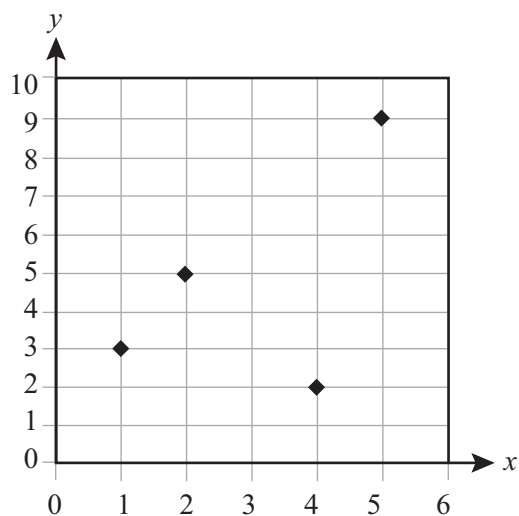

What is the value of y when $x = 2$?

- A 3
- B 4
- C 5
- D 9

MATHEMATICS

6. Workers dug a hole for the basement of a new home. The hole was 40 feet long, 20 feet wide, and 10 feet deep. What was the volume of the hole that the workers dug?
- A 140 cubic feet
 - B 800 cubic feet
 - C 2,000 cubic feet
 - D 8,000 cubic feet
-

7. The picture below shows the time on the clock in Parker's bedroom.

Parker's Clock

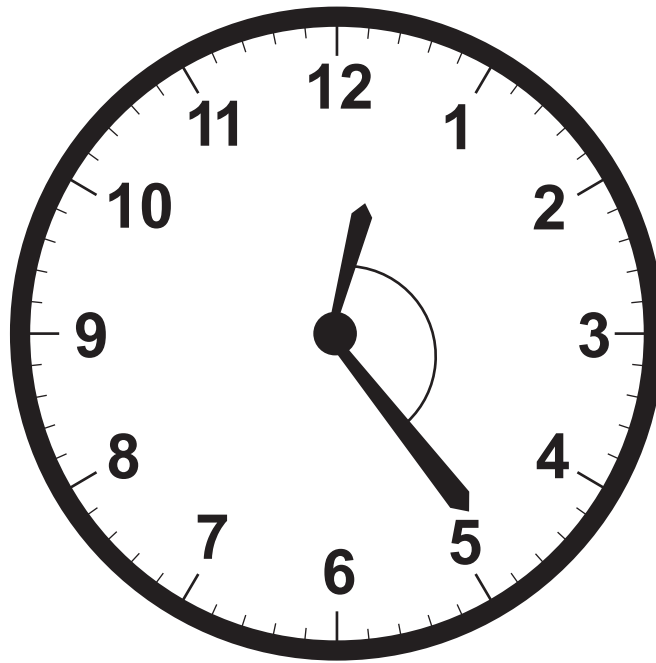

What is the measure of the angle between the hour and minute hands on the clock?

- A 22°
- B 51°
- C 69°
- D 129°

MATHEMATICS

8. At Greg's party, $\frac{2}{3}$ of the guests wanted pizza. Of those guests, $\frac{4}{5}$ wanted cheese pizza. What fraction of Greg's guests wanted cheese pizza?

A less than $\frac{2}{3}$
B exactly $\frac{2}{3}$
C between $\frac{2}{3}$ and $\frac{4}{5}$
D more than $\frac{4}{5}$

9. Joan has a photo that is 4 inches wide and 6 inches long. She is enlarging the photo by a scale of 1 to 2.5. What is the new measure of the length?

A 8.5 inches
B 9.0 inches
C 10.0 inches
D 15.0 inches

10. Justin and Marissa will follow a map for their hike. On the map, 1 centimeter represents 1.5 kilometers. The length of their hike is 8 centimeters on the map. How many kilometers is the hike?

A 6.5 kilometers
B 9.5 kilometers
C 12 kilometers
D 16 kilometers

MATHEMATICS

11. A coyote runs at a top speed of 43 miles per hour. An antelope runs at a top speed of 61 miles per hour. The equation below shows the relationship between the coyote's top speed and the antelope's top speed.

$$43 + x = 61$$

How much faster in miles per hour (x) does the antelope run than the coyote?

- A 18
 - B 61
 - C 52
 - D 104
-

12. Alex is measuring part of the school playground for a basketball court. Which unit of measure would Alex most likely use?

- A square centimeters
 - B square inches
 - C square yards
 - D square miles
-

13. Jon is taking a trip. He measures the distance of his trip on a map as $2\frac{1}{2}$ inches. The scale on the map is 1 inch = 50 miles. What is the total distance of Jon's trip?

- A 20 miles
- B 52.5 miles
- C 100.5 miles
- D 125 miles



MATHEMATICS

14. Renee wants to order fishing poles for her tour group. The table below shows the total cost (c) of ordering n poles.

Fishing Poles

Number (n)	Total Cost (c)
3	\$120
4	\$140
5	\$160
6	\$180
7	\$200

Which equation shows the relationship between the number of poles ordered, n , and the total cost, c ?

- A $c = 3n + 120$
B $c = 4n + 180$
C $c = 20n + 60$
D $c = 40n$
-
15. Walter bought 2.5 yards of fabric at \$3.70 per yard. How much did Walter pay for the fabric?
- A \$7.95
B \$8.25
C \$8.95
D \$9.25

Turn to page 24 in your answer booklet to complete question 16.

MATHEMATICS

17. What is 797.95 expressed in expanded notation?

- A $(7 \times 100) + (9 \times 10) + (7 \times 1) + (9 \times 0.1) + (5 \times 0.01)$
 - B $(7 \times 100) + (9 \times 10) + (7 \times 1) + (9 \times 0.01) + (5 \times 0.001)$
 - C $(797 \times 100) + (95 \times 0.01)$
 - D $(797 \times 100) + (0.95 \times 0.01)$
-

18. Terry bought 4 pounds of strawberries for \$11. Which equation can be used to find the cost per pound of strawberries (x)?

- A $11 + x = 4$
- B $4x = 11$
- C $4 + x = 11$
- D $11 = \frac{x}{4}$

MATHEMATICS

19. A librarian receives 2 fiction books for every seventh grader (s) at his school and 3 non-fiction books for every eighth grader (e). The expression below represents the number of books he receives.

$$2s + 3e$$

This year there were 13 seventh graders and 8 eighth graders. How many books did the librarian receive this year?

- A 5 books
 - B 21 books
 - C 50 books
 - D 55 books
-

20. How many faces does a triangular pyramid have?

- A 3
- B 4
- C 6
- D 9

MATHEMATICS

21. The diagram of a chair is pictured below.

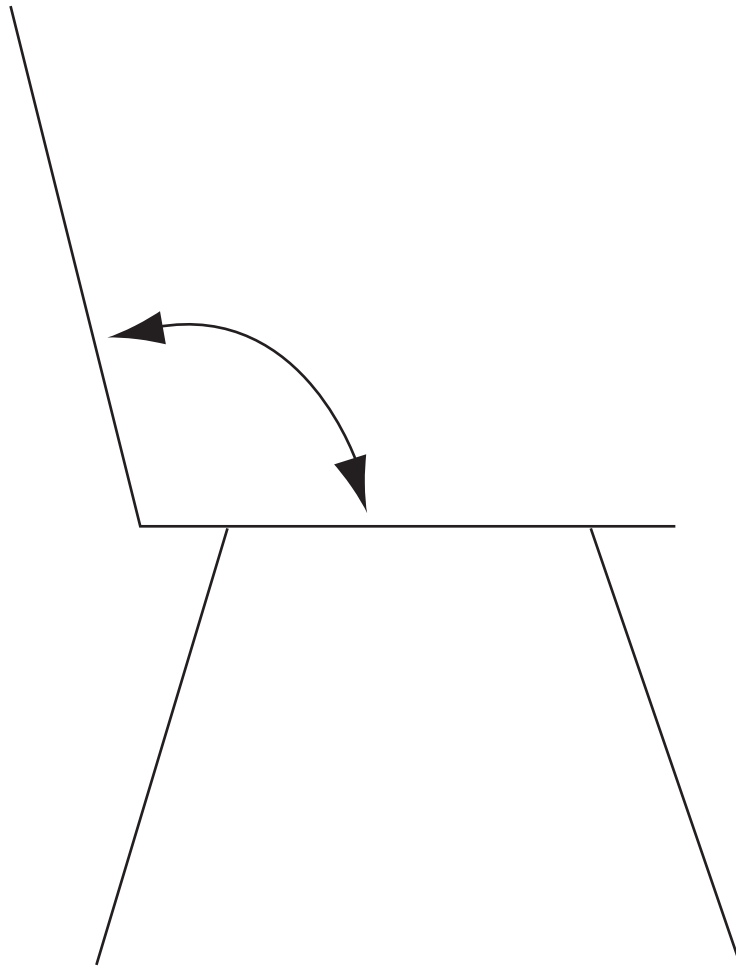

What is the measure of the angle made where the backrest meets the seat of the chair?

- A 76°
- B 84°
- C 104°
- D 116°

MATHEMATICS

22. The graph below shows the total points for 5 hockey players in a season.

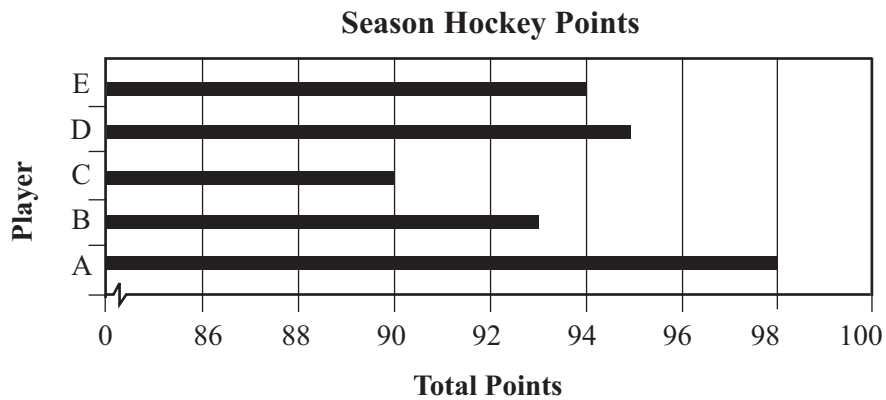

What conclusion can be drawn from the graph?

- A Player D had more points than Player A.
- B Player A had the most points of the 5 hockey players.
- C All 5 of the hockey players had between 90 and 95 points.
- D Player A played the most games in the season.

23. What is the value of $p - p(0.10)$ when $p = \$60.00$?

- A \$54.00
- B \$59.90
- C \$60.10
- D \$66.00

MATHEMATICS

24. Brenda wanted to see how much water evaporated from an open container. She measured 14.386 liters in the container at the beginning of the day and 13.987 liters 12 hours later. How many liters evaporated during those 12 hours?

A 0.399 liter
B 0.401 liter
C 0.409 liter
D 0.499 liter

25. Juan has already written 9 pages in his notebook. He writes 3 pages each week. How many pages will Juan have written in his notebook after 4 more weeks?

A 12
B 13
C 21
D 27

26. Cedric has \$0.45 in his pocket. Which fraction of a dollar does Cedric have?

A $\frac{9}{20}$
B $\frac{11}{20}$
C $\frac{4}{5}$
D $\frac{9}{10}$

MATHEMATICS

27. Randy used the expression below to find the cost of renting a shed for a certain number of months (m).

$$45 + 125m$$

What is Randy's cost to rent the shed for 3 months?

- A \$170
 - B \$173
 - C \$260
 - D \$420
-

28. Lee built a scale model of his car. The model was 3 inches long. The scale from the model to Lee's car was 1 to 60. What was the length of Lee's car?

- A 20 inches
 - B 57 inches
 - C 63 inches
 - D 180 inches
-

29. The Jones family has five children. The ages of the children are listed below.

9, 5, 14, 5, 7

What is the median age of the children?

- A 5
- B 7
- C 8
- D 14

MATHEMATICS

30. Violet made a mirror in the shape of a regular pentagon. Which must be true about the diagonals of the pentagon-shaped mirror?
- A 3 of the diagonals are twice as long as the other 2.
 - B All of the 5 diagonals are exactly the same length.
 - C All of the diagonals intersect at right angles to each other.
 - D Each of the 5 diagonals has a different length.
-

31. An orange slice is shown below.

Orange Slice

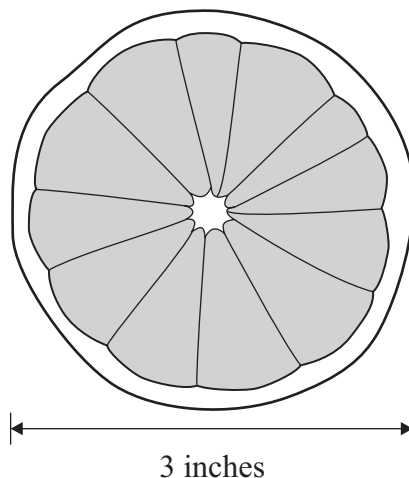

The orange slice is shaped like a circle. The diameter of the orange slice is 3 inches. What is the circumference?

- A 1.5π
- B 3π
- C 6π
- D 9π

MATHEMATICS

32. Clara examines the following function.

x	y
1	4
2	11
3	18
4	25
5	32

What is the correct description of the function that gives these results for y ?

- A add 3 to x
 - B add 7 to x
 - C multiply x by 5, then subtract 1
 - D multiply x by 7, then subtract 3
-

33. A campsite provides a locking, rectangular box with the dimensions shown below to secure food from bears.

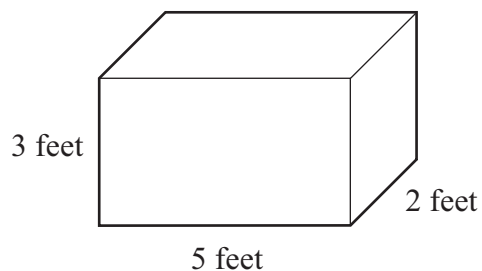

What is the surface area of the box?

- A 30 square feet
- B 31 square feet
- C 62 square feet
- D 72 square feet

MATHEMATICS

34. Reyna is sewing curtains for a theater stage. She needs to measure the area the curtains will cover in order to buy fabric. Which unit of measure would be **best** to use?

A square centimeters
B square kilometers
C square miles
D square yards

35. What is the value of the expression $0.05x + 0.10y + 0.25z$ when $x = 2$, $y = 3$, and $z = 4$?

A 1.00
B 1.40
C 3.60
D 9.40

MATHEMATICS

36. A battery is shown below.

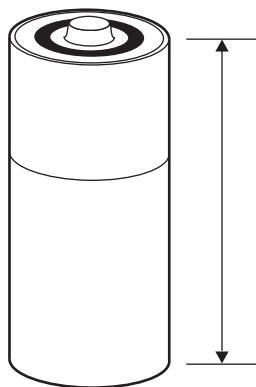

What is the length of the battery, to the nearest $\frac{1}{16}$ inch?

- A $1\frac{5}{16}$ inches
- B $1\frac{11}{16}$ inches
- C $2\frac{5}{16}$ inches
- D $2\frac{11}{16}$ inches

MATHEMATICS

37. The heights, in centimeters, of 10 people in Lakesha's class are shown below.

98, 113, 108, 105, 105, 111, 108, 120, 110, 117

Which stem and leaf plot represents the heights of the people?

A **Height**

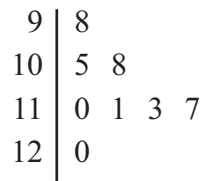

Key

10 | 7 = 107

B **Height**

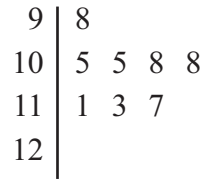

Key

10 | 7 = 107

C **Height**

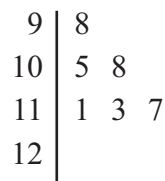

Key

10 | 7 = 107

D **Height**

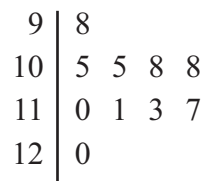

Key

10 | 7 = 107

-
38. Jill is flying from Anchorage, Alaska to Key Largo, Florida. Her plane leaves Anchorage at 5:00 AM and her flight lasts 8 hours. The time in Florida is 4 hours later than in Alaska. What time will Jill arrive in Key Largo, Florida?

- A 1:00 AM
- B 9:00 AM
- C 1:00 PM
- D 5:00 PM

MATHEMATICS

39. What is the name of the polygon with exactly 9 diagonals?
- A hexagon
 - B pentagon
 - C quadrilateral
 - D triangle
-

40. Rita snowboarded x feet. Nathan snowboarded 438 feet less than twice as far as Rita. The expression below represents the distance Nathan snowboarded.

$$2x - 438$$

Which is an equivalent expression?

- A $438 + 2x$
- B $438 - 2x$
- C $-438 + 2x$
- D $-438 - 2x$

MATHEMATICS

41. Jordan is making a necklace. She adds the same number of beads to the necklace each day. The table below shows the total number of beads at the end of each day.

Jordan's Necklace

Day	Total Beads
1	3
2	8
3	13
4	18
5	
6	
7	?

The pattern in the table continues. How many total beads does the necklace have at the end of Day 7?

- A 21 beads
 - B 33 beads
 - C 35 beads
 - D 42 beads
-

42. Mandy made a circular flower garden with a diameter of 7 feet. She wants to put a fence around the outside of the garden. About how much fence does Mandy need to buy? (Use 3.14 for π .)

- A 11 feet
- B 22 feet
- C 38 feet
- D 44 feet

Turn to page 26 in your answer booklet to complete question 43.

MATHEMATICS

44. Sam is 15 years old. Sam is 5 years older than Andy. Which equation represents Andy's age (A)?

A $5A = 15$

B $A - 5 = 15$

C $A + 5 = 15$

D $\frac{A}{5} = 15$

45. A school bus used 6 gallons of gas on Monday and twice that amount on Tuesday. The total amount of gas used on these two days was $6 + 2(6)$ gallons. What is another way to write the expression $6 + 2(6)$?

A $2(6 + 6)$

B $(6 + 2)6$

C $6 + (6)2$

D $6 + 2 + 6$

46. Jeri bought her friend Lynn 1 scoop of ice cream in a cone. The store had 6 flavors (vanilla, chocolate, strawberry, mint, rocky road, and coffee) along with 2 different types of cones (waffle and regular). What is the probability that Jeri randomly selected a scoop of chocolate ice cream in a waffle cone for Lynn?

A $\frac{1}{12}$

B $\frac{1}{6}$

C $\frac{1}{3}$

D $\frac{2}{3}$

MATHEMATICS

47. The weight of a newborn tiger is shown in the table below.

Weight of Tiger

Age (weeks)	Weight (pounds)
0	3
1	5
2	7
3	9
4	11

Which equation **best** represents the relationship between the age (a) of the tiger and its weight (w)?

- A $w = 2a + 3$
 - B $w = 3a + 2$
 - C $a = 2w + 3$
 - D $a = 3w + 2$
-

48. Sanjay recorded the density of various substances at 25° Celsius, as shown in the table below.

Density of Substances at 25°C

Substance	Density (grams/cm ³)
aluminum	2.70
gold	19.3
water	0.997
copper	8.92

He then wrote the densities in order, from least to greatest. What is the correct order of the given numbers, from least to greatest?

- A 19.3, 8.92, 0.997, 2.70
- B 0.997, 2.70, 8.92, 19.3
- C 19.3, 2.70, 8.92, 0.997
- D 0.997, 2.70, 19.3, 8.92

MATHEMATICS

49. Rosa made a scale drawing of the front of a rectangular building. The height of the building in her drawing is 4 inches and the width is 8 inches. The scale from the drawing to the building is 1 inch to 12 feet. What is the actual height of the building?
- A 3 feet
B 16 feet
C 48 feet
D 96 feet
-

50. The diagram below shows a rectangular patch that Sam will use to repair a sail.

Patch for Sam's Sail

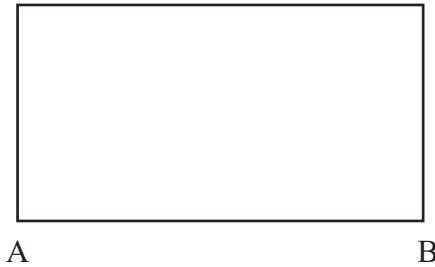

The length of the patch is indicated by \overline{AB} in the diagram. What is the length of \overline{AB} in the diagram?

- A $1\frac{7}{8}$ inches
B $2\frac{1}{8}$ inches
C $2\frac{1}{4}$ inches
D $3\frac{1}{8}$ inches

MATHEMATICS

51. The circle graph below shows favorite flavors of jellybeans based on a random survey of 50 people.

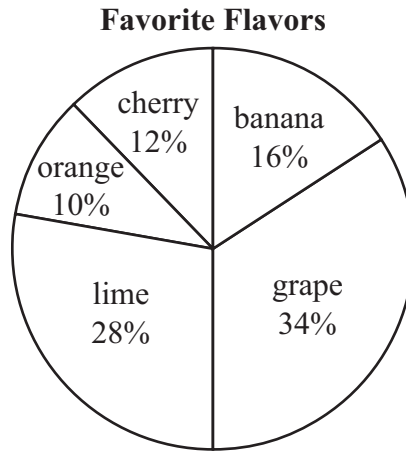

How many more people chose grape than cherry as their favorite flavor?

- A 11 people
 - B 22 people
 - C 23 people
 - D 46 people
-
52. Travis bought a rectangular prism-shaped storage container for his backyard. It measured 6 feet long, 4 feet wide, and 2 feet high. What is the volume of the storage container?
- A 12 cubic feet
 - B 24 cubic feet
 - C 48 cubic feet
 - D 88 cubic feet

MATHEMATICS

53. Michael drew a square as shown in the figure below.

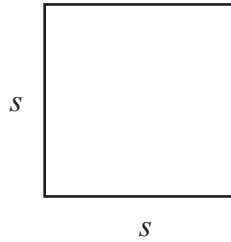

He knows the formula for the area of a square is $A = s^2$. How would the area of the square change if he were to make the length of each side 3 times as long?

- A The area would be 3 times larger.
 - B The area would be 6 times larger.
 - C The area would be 9 times larger.
 - D The area would be 12 times larger.
-

54. Brienne made the triangular design shown below.

Brienne's Design

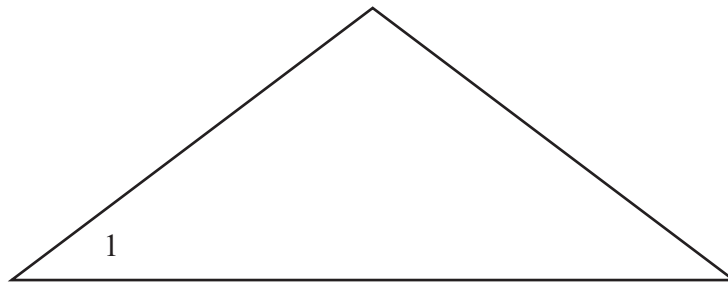

What is the measure of $\angle 1$?

- A 37°
- B 43°
- C 143°
- D 157°

MATHEMATICS

55. Kim is playing a game using the spinner shown below.

Kim's Spinner

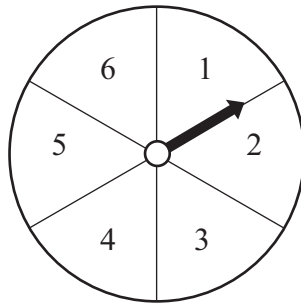

What is the probability that the arrow will land on a number greater than 4 on Kim's next spin?

- A $\frac{1}{6}$
 - B $\frac{1}{3}$
 - C $\frac{1}{2}$
 - D $\frac{2}{3}$
-

56. Sarah has a box in the shape of a rectangular prism. It is 8 inches wide by 10 inches long by 5 inches high. What is the surface area of Sarah's box?

- A 170 square inches
- B 340 square inches
- C 400 square inches
- D 480 square inches

MATHEMATICS

57. John's locker number is a 2-digit prime number. Which could be John's locker number?

- A 91
 - B 93
 - C 97
 - D 99
-

58. A rectangular playground is shown below.

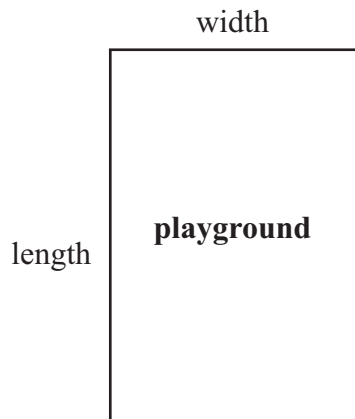

The area of the playground was increased by doubling the width. The length stayed the same. By how much did the area of the playground change?

- A The area is $\frac{1}{2}$ times as large.
- B The area is $1\frac{1}{2}$ times as large.
- C The area is 2 times as large.
- D The area is 4 times as large.

Turn to page 28 in your answer booklet to complete question 59.

END SESSION

